

SUDURNES REGIONAL HEATING CORP.

Edited by Paul J. Lienau
Geo-Heat Center

INTRODUCTION

The Svartsengi geothermal area is close to the town of Grindavik on the Rekjanes peninsula and is part of an active fissure swarm, lined with crater-rows and open fissures and faults. The high-temperature area has an area of 2 sq. km and shows only limited signs of geothermal activity at the surface. The reservoir, however, contains lots of energy and at least 8 wells supply the Svartsengi Power Plant with steam. The steam is not useable for domestic heating purposes so that heat exchangers are used to heat cold groundwater with the steam. Some steam is also used for producing 16.4 MW_e of electrical power. Figure 1 shows the distribution system piping hot water to nine towns and the Keflavik International Airport. The effluent brine from the Svartsengi Plant is disposed of into a surface pond, called the Blue Lagoon, popular to tourists and people suffering from psoriasis and other forms of eczema seeking therapeutic effects from the silica rich brine. This combined power plant and regional district heating system (co-generation) is an interesting and unique design for the application of geothermal energy.

In 1969, the Grindavik municipal council decided to have a study made of harnessing geothermal energy in the Svartsengi area to heat houses in the village. The wells drilled at that time, 240 and 430 m deep, looked very promising, while there was some disappointment as they revealed that:

- this was a high-temperature geothermal area (i.e. with temperatures rising to more than 200°C at less than 1000 m depth, and
- the geothermal reservoir contained water with about two thirds of the salinity of the sea.

Due to the level of salinity and the high temperature of the water, it was clear that it would not be possible to utilize the geothermal fluid directly as had been the case in Reykjavik and most other places in Iceland; what was needed was the development of a method of heat exchange to facilitate the utilization of the geothermal power. In January 1973 the National Energy Authority (NEA) completed its preliminary plans for a geothermal plant in the Svartsengi area. The results of these plans were very encouraging, urging further research, which the Authority undertook for the entire area. Two wells were drilled, 1,713 m and 1,519 m deep and a resistivity survey made to ascertain the size of the geothermal areas. These measurements revealed that the size of the hot-water reservoir at a depth of about 600 m was roughly 400 hectares. By 1993, a total of 14 high-temperature wells were drilled in the Svartsengi area, totaling 13.6 km in depth, the deepest one being about 2,000 m; two of the wells were never productive,

four have become inactive, and the drilling of one was only preliminary. A summary of the project development follows:

- 1971-72 The first two wells drilled. They disclosed a reservoir temperature of about 235°C and highly saline water with total dissolved solids of about 20,000 to 30,000 ppm, which could not be used directly in a district heating system.
- 1972-73 National Energy Authority published a feasibility report for a district heating system. Production cost of geothermal energy estimated at about 1/3 that of oil-fired heating.
- 1974 A pilot plant was built by NEA. Two wells drilled (HSH-4/1713 m; HSH-5/1519 m). Sudurnes Regional Heating Company (SRHC) established, owned 60% by the regional communities and 40% by the Icelandic state.
- 1976-77 A preliminary power plant of 3 MW_t commissioned. Power plant I of 12.5 MW_t was commissioned.
- 1978 First 1 MW_e turbogenerator commissioned. Second unit of power plant I of 12.5 MW_t commissioned. Well HSH-6 drilled (1734 m).
- 1979-80 Third and fourth units of power plant I of 2 x 12.5 MW_t commissioned. Second 1 MW_e and third 6 MW_e turbogenerator units commissioned. Wells HSH-7 (1438), HSH-8 (1603 m), HSH-9 (994 m), HSH-10 (425 m) and HSH-11 (1141 m) drilled.
- 1981 Power plant II of 75 MW_t commissioned. Well HSH-12 (1488 m) drilled for injection tests.
- 1989-92 Seven binary power units of 8.4 MW_e were commissioned.

PROCESSING METHOD

Geothermal brine cannot be used directly for heating because of its high mineral content. On cooling, it releases great quantities of hard deposits (silica) which lodge themselves onto pipes and other equipment, making such equipment inoperable after a short time.

For this reason, the geothermal brine is made to boil twice and the heat from the steam thus formed is utilized, while deposits from the steam are minimal. As shown in Figure 1 high-pressure geothermal steam (5.2-5.5 bars) is

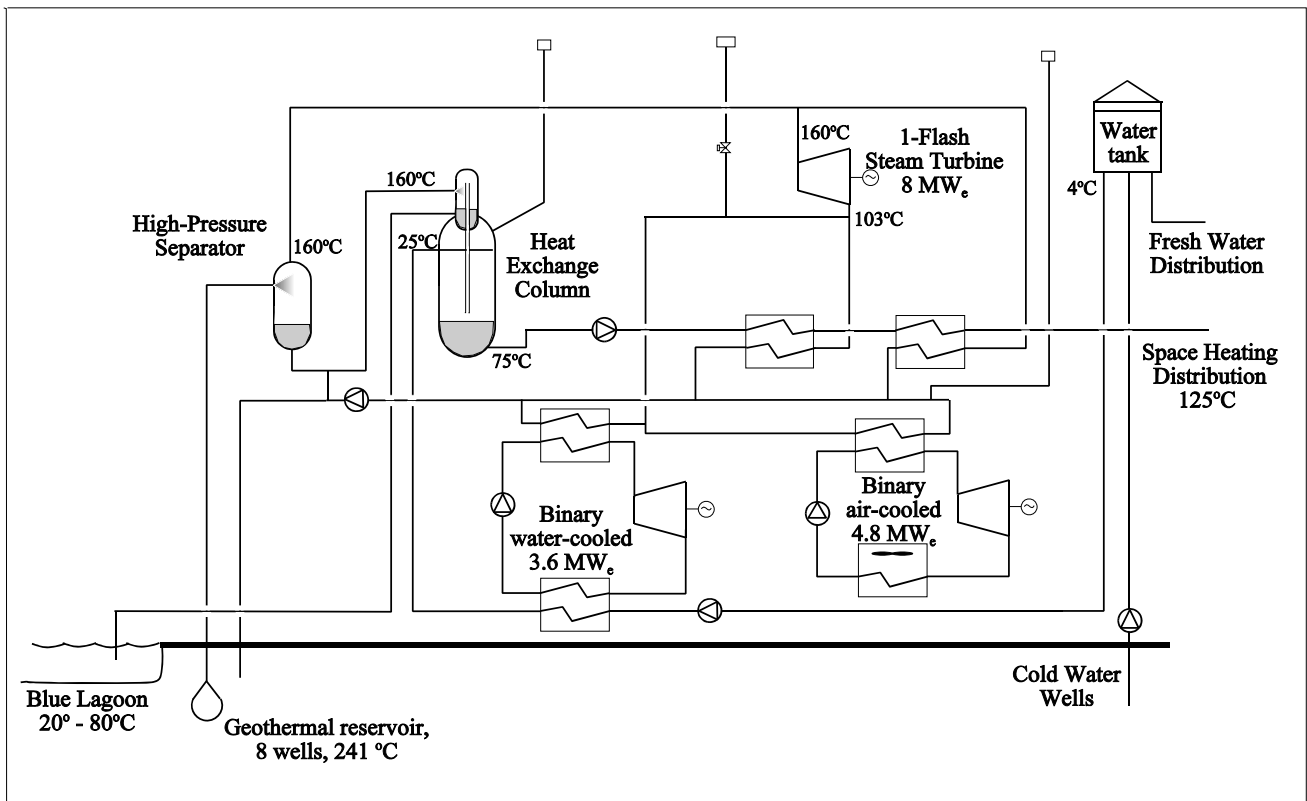
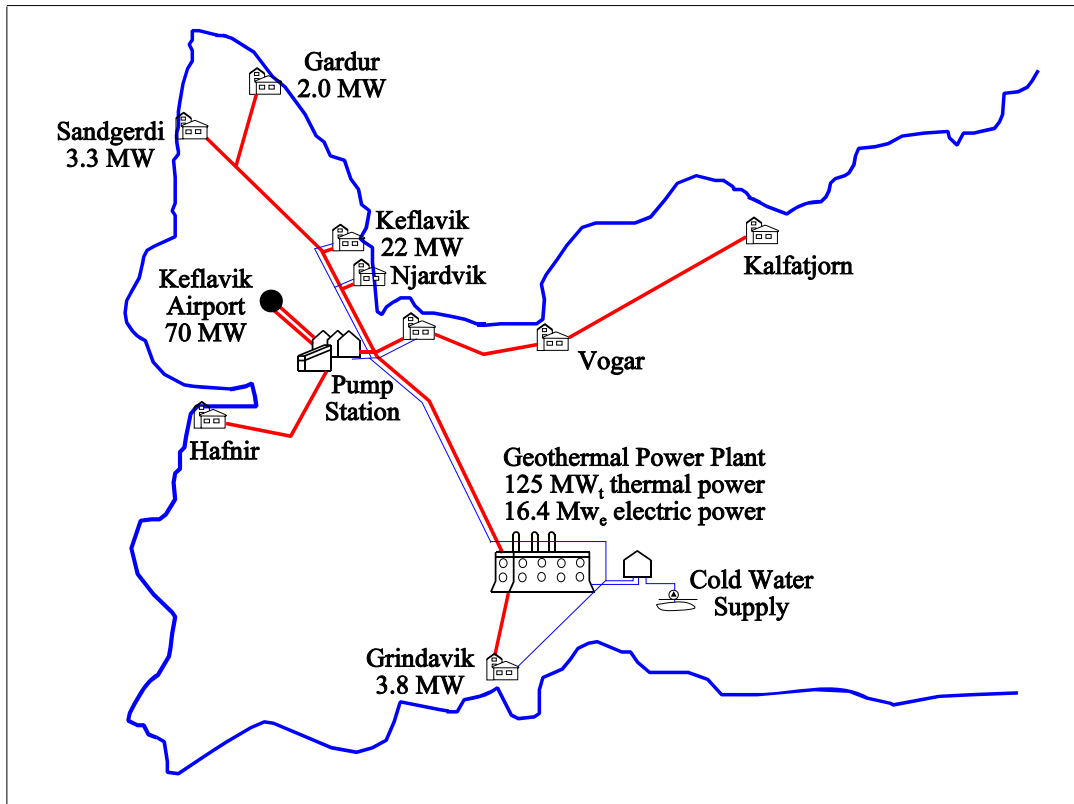

Figure 1. The Sudurnes Regional Heating System layout and flow diagram for Svartsengi Power Plant.

harnessed in steam turbines for the generation of electricity (8 MW_e), and for the final heating of the utility water (100° -120°C). Low-pressure geothermal steam (80° -104°C) is used for the direct warm-up of fresh water (preheating) and for the generation of electricity (8.4 MW_e) in ORMAT binary generators.

Thus, fresh water is warmed up (from 4°C to 25°C) in the ORMAT generators, de-gassed and heated with low-pressure steam to about 75°C in direct-contact heat exchangers. Then it is heated to about 100°C in a plate heat exchanger with 105° -110°C hot steam coming out of the exhaust from steam turbines; and finally, the water is superheated with high-pressure steam to about 100° -125°C in a plate heat exchanger.

The power generated by the power station amounts to 125 MW_t in the form of hot water, assuming the water is 125°C on leaving the power station and 40°C hot when discarded by the end users, and 16.4 MW_e of electricity.

DISTRIBUTION SYSTEM

The distribution system of the SRHC covers all the local government areas in the district, in addition to Keflavik Airport (Figure 1). In 1993, the total length of the distribution system and supply systems comes to about 340 km. There is only a single piping system in the local government areas, but at Keflavik Airport there is a closed-circuit system, enabling the utility to return the back flow to a pumping station. Supply lines from Svartsengi and collection pipes from production wells at Svartsengi are located above ground, insulated with mineral wool, which is covered with a dimple plastic sheet and clad with aluminum sheets. All other pipes are located underground inside the boundaries of built-up areas; thus, they do not constitute any hindrance or an eyesore in the landscape.

Water from the power station is at two temperatures. Water pumped to Grindavik leaves the power station at 83°C and arrives at the village boundary at about 80°C, while water piped to the pumping station at Fitjar leaves at 105° -120°C, as this water is mixed with back-flow water from the airport area and then pumped to the end users at 83°C, and 90°C to the airport area. It is expected that the end users utilize the heat in the water down to 35° -40°C, and then the water runs out to the sea through the sewer systems of the local government areas.

A large quantity of cold water, up to 330 L/s, is extracted from a perched aquifer at Gja and other places. Water extraction for the water works averages about 190 L/s. However, there is thought to be little risk of the water extraction rate being too high, as the average precipitation in an area of 10-15 km² is expected to equal the entire water supply of the SRHC; the total area of the Reykjanes peninsula is about 580 km².

ELECTRICITY GENERATION

At the power station, high-pressure steam has been used to generate electricity almost from the beginning; thus, in 1978, two 1-MW_e geothermal steam turbines were installed for the purpose of generating electricity for use at the power station and pumping station themselves. In December 1980, a 6-MW_e Fuji steam turbine was put into operation, generating electricity

for the grid. During the next few years the three turbines generated about 40 GWh per year, including about 10 GWh for the stations. Through the merger of the power distribution systems in 1985, it became possible to utilize the turbines better, increasing the production to about 60 GWh per year.

On 8th September 1989, the next step was taken with the start up of three 1.2-MW_e binary ORMAT turbines (water-cooled), utilizing steam which had previously flowed unharnessed from the chimneys of the power station. The production went up to about 90 GWh per year, including about 15 GWh for the stations. The latest increase in electricity generation came on the 5th of March 1993, when four additional 1.2-MW_e binary turbines (air-cooled) were put into operation. Installed power at the station then rose to 16.4 MW_e, and production is expected to rise in stages during the next few years to 110 GWh, including 17 GWh for the plant's own use.

THE BLUE LAGOON

In 1981, people suffering from psoriasis tried bathing in the Blue Lagoon with fairly promising results. This encouraged interest in the Lagoon and several studies have since been made of its healing properties. In the light of increased attendance, the SRHC in 1986 decided to construct a bathhouse by the Lagoon. The building was then enlarged in 1988 as attendance kept increasing steadily. The Grindavik municipality took over the operation of the bathing facility in 1992 and erected an annex to the building, which has come in good stead as the number of guests came to more than 133,000 in 1993, including 108,000 actual bathers.

Great efforts are being made to work on further development and utilization of the possibilities offered by the Blue Lagoon. Preliminary plans have been made for the construction of a new lagoon under the western slopes of the mountain Thorbjorn, at a distance of about 2 km from the present one, where there are plans to construct extensive health and tourist facilities. Although some people prefer the present location next to the power plant, which provides an additional attraction. The Health Company by the Blue Lagoon Ltd has prepared special bathing facilities for psoriasis patients. Studies of the healing powers of the lagoon are being made there under the strict supervision of dermatologists. Furthermore, the company has started experiments in preparing lotions, creams, etc., containing silica and salts from the Lagoon; algae living in the Lagoon are being cultivated at a special research facility.

There are hopes that these activities, along with other possibilities connected to the Blue Lagoon, will prove to be the mainstay of the economy of the area in the future.

REFERENCES

- Sudurnes Regional Heating Corp. pamphlet, 1994. SRHC, Brekkustigur 36, 260 Njardvik, Iceland.
- Bjornsson, G. and A. Albertsson, 1985. "The Power Plant at Svartsengi, Development and Experience", Proc. 1985 International Symposium on Geothermal Energy, Geothermal Resources Council, Davis, CA.