

# DESCRIPTION AND OPERATION OF HAAKON SCHOOL GEOTHERMAL HEATING SYSTEM

F. W. Childs\*, L. D. Kirol\*, R. D. Sanders\*, and M. J. McLatchy\*\*

\*EG&G Idaho, Inc.

\*\*U.S. Department of Energy, Idaho Operations Office

## INTRODUCTION

Haakon School is located in the city of Philip, near the Badlands National Park in the southwest quadrant of South Dakota. The town overlies the Madison Formation which is a large-area aquifer. The aquifer has a demonstrated capability to produce geothermal water. A system to tap this potential and heat the Haakon School District buildings in Philip has been in operation since November 1980. Five school buildings having a total area of 44,000 ft<sup>2</sup> (4088 m<sup>2</sup>) are heated with 157°F (69°C) water. A single well provides water at a maximum artesian flow of 340 gpm (21.5 L/s, which more than meets the heat demand of the school buildings). Eight buildings in the Philip business district utilize geothermal fluid discharged from the school for space heating. During the 1980-81 heating season, these buildings obtained 75% to 90% of their heat from geothermal fluid. Peak heat delivery of the system is 5.5 million Btu/h (1.61 MJ/s), with an annual energy delivery of 9.5 billion Btu (10 TJ).

The geothermal system has operated nearly problem free with the exception of the equipment to remove Radium-226 from the spent fluid. Barium chloride is added to the water to precipitate sulfates containing the radium. Accumulation of precipitates in piping has caused some operational problems.

## SYSTEM DESCRIPTION

Geothermal water flows from the well at 157°F (69°C) and is first used to heat the armory/high school building and elementary school buildings. Fluid discharged from the schools and armory is then used for space heating of buildings in the Philip business district. Spent geothermal fluid is treated for Radium-226 removal prior to disposal in the Bad River. A flow diagram for the system is shown in Figure 1.

The artesian well is located about 170 ft (52 m) northwest of the armory/high school building. Total depth of the well is 4,266 ft (1,300 m), and maximum flow is 340 gpm

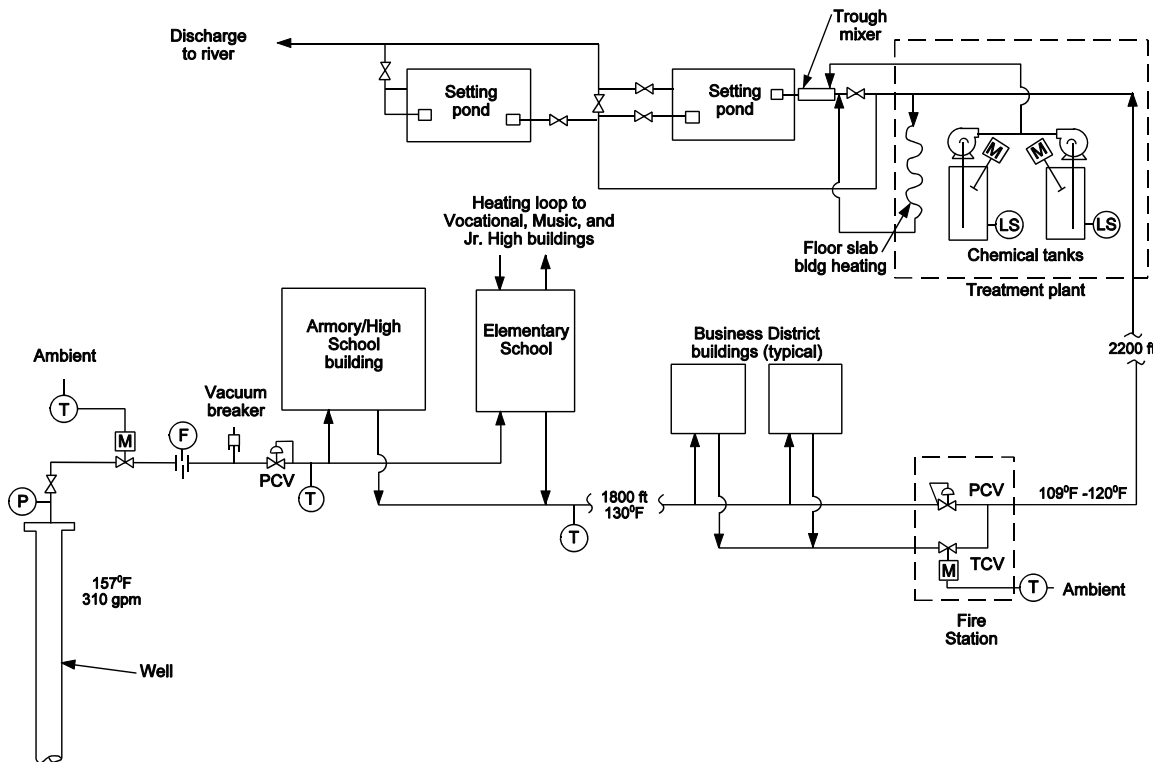
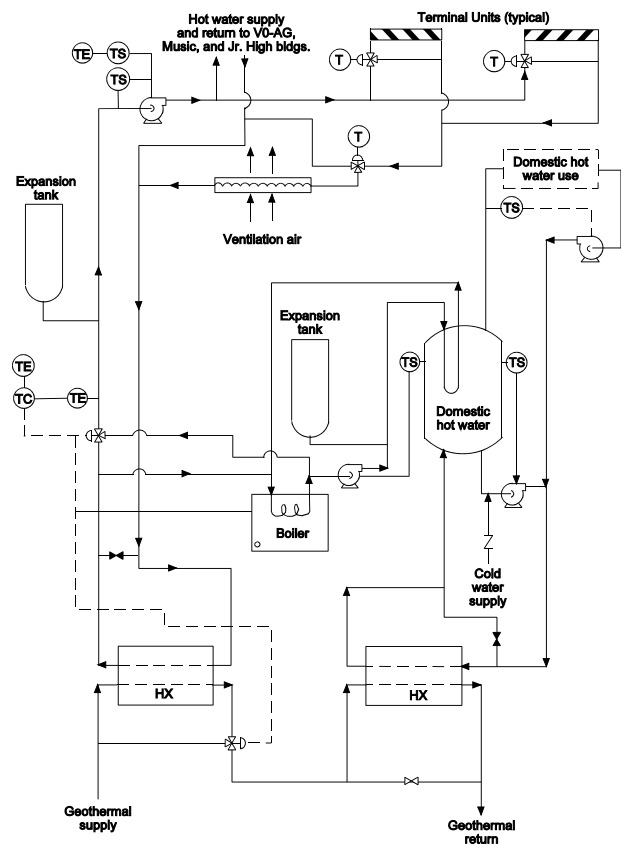

Figure 1. Haakon School geothermal system schematic.

(21.5 L/s). The water has a total dissolved solids content of 1,112 ppm and a pH of 7.4.

Buildings heated by the geothermal fluid include the high school building (also heating the National Guard Armory), the elementary school building, a vocational-agricultural education building, and two music buildings. The floor area of the high school building is 20,088 ft<sup>2</sup> (1,866 m<sup>2</sup>), and the elementary school building is 15,356 ft<sup>2</sup> (1,427 m<sup>2</sup>). Both buildings were previously heated with oil-fired steam boilers. The 6,252 ft<sup>2</sup> (581 m<sup>2</sup>) vocational building previously had electrical resistance heating. Propane space heaters were used in the 1,550 ft<sup>2</sup> (144 m<sup>2</sup>) instrumental band and 792 ft<sup>2</sup> (74 m<sup>2</sup>) vocal music buildings.

Water and space heating equipment in the elementary school boiler room is shown schematically in Figure 2. The armory boiler room is very similar. Buried, fiber reinforced plastic pipe transports the geothermal fluid to the two boiler rooms. There it passes through two plate-type heat exchangers.



**Figure 2. Haakon Elementary School geothermal heating schematic.**

The exchangers are off-the-shelf items. Each unit uses 316 stainless steel plates and nitrile gaskets. One unit heats water in a closed heating loop and the second heats domestic hot water. The elementary school boiler was modified to convert it from steam to hot water production. The armory boiler was in poor condition and was replaced with several, small new hot-water units. Both boiler systems are in series with the geothermally-heated hydronic systems to provide

backup and peaking. Backup domestic water heating is provided by the boilers via a heat exchanger in the domestic hot water storage tank. Since the initial startup, the boilers have only been needed once. That was during a 2-hr period when the wind chill was -55°F (-48°C). In addition to heating the elementary school, the hydronic system also supplies the vocational-agriculture and music buildings. The junior high school is in the process of being added to the system.

Terminal units included modified and new equipment. Ventilators, fan coils, and unit heaters were modified to accept water coils in place of steam coils. Baseboard radiation units are used, as is; but, additional units were added to maintain heat capacity with 145°F (63 °C) water instead of 225 °F (107°C) steam.

The geothermal discharge from the school is transported in a single pipe which becomes the supply line through the downtown area. A disposal line begins at the upstream end of the business district and parallels the supply line from the school to the last user on the system, the fire station. From there, a single line continues to the radium removal plant and disposal in the Bad River.

Eight buildings in the business district are presently connected to the system. Application methods vary, although all use fan coils of some sort. Some use the geothermal water directly in existing coils, some in new copper coil unit heaters or coils placed in existing duct work. One uses new stainless steel coils in existing duct work, and one uses a shell-and-tube heat exchanger to heat a hydronic loop.

Water leaving the business district flows to the water treatment plant where Radium-226 is removed. The water is then discharged to the Bad River. The geothermal fluid naturally contains about 100 pCi/L (pico Curies/liter) of Radium-226 as radium sulfate. The allowable EPA limit for drinking water is 10 pCi/L (5 pCi/L background plus 5 pCi/L in the fluid).

Barium chloride (as 10% aqueous solution) is added to the water to cause formation of barium sulfate from sulfates already present. Barium sulfate and radium sulfate then coprecipitate. Precipitates are allowed to settle in the pond (3-day retention time) before water is discharged to the Bad River.

The barium chloride addition rate is fixed to give 2.6 ppm BaCl<sub>2</sub> at maximum geothermal flow. Automatic adjustment to maintain this concentration at lower flow is not provided. Barium chloride mix tanks and pumps are housed in the water treatment building. The solution is added at a baffled trough which empties into the pond. Only one pond is in use.

Sludge collects on the pond bottom at a rate of about 85 ft<sup>3</sup> (2.3 m<sup>3</sup>) per year. Sufficient liquid volume will be maintained throughout the pond's 30-year life. Radioactivity accumulates at 0.06 curies/year. At the end of pond life, the sludge can be removed to a disposal site or mixed with cement to form the bottom for a new pond build directly over the old one.

Control points for the system are shown schematically in Figures 1 and 2. Flow of geothermal fluid from the well is regulated by a valve and controller responding to ambient temperature. Full flow is achieved at, and below,

30°F (-1°C) and minimum flow (about one third open) occurs between 60 and 65°F (16 and 18 °C). Minimum flow is maintained at higher temperatures to provide energy for domestic hot water heating. A pressure reducing valve located just downstream of the flow control valve maintains approximately 20 psig (138 kPa) in the system leaving the well house.

Equipment in the fire station (downstream of the business district distribution system) controls system pressure and regulates flow through the business district loop. A motor operated flow control valve on the return line is set to be full open at 20°F (-7°C) and full closed at 65°F (18°C). A second valve maintains back pressure in the distribution piping to minimize calcite precipitation.

The temperature of the hydronic fluid leaving the geothermal heat exchangers and ambient temperature determine geothermal flow rate to the heat exchangers. The temperature of the hydronic fluid is maintained between 90 and 140°F (32 and 60°C). Circulation in the heating loop is controlled by ambient and fluid temperatures. Pumps are activated at outside temperatures below 64°F (18°C) and are shut off when temperature exceeds 66°F (19°C) and no heat is needed. The pumps are also deactivated when hydronic fluid temperature is below 65°F (18°C). This avoids wasting pumping energy. Room thermostats control flow through terminal units.

When outside temperature is below -10°F (-23°C) and hydronic fluid temperature is below 90°F (32°C), the backup boiler is turned on and automatically valved into the system. During boiler operation, hydronic fluid flows first through the geothermal heat exchanger, and then through the boiler.

The geothermal fluid flows continuously through the domestic water heat exchanger. Flow of portable water through the heat exchanger occurs during make up due to water consumption and when the recirculating pumps are running. One pump operates as needed to circulate a small flow through the building supply loop to maintain a ready supply of hot water at the taps. The second pump starts automatically when storage tank temperatures falls below 115°F (46°C) and circulates water from the tank through the heat exchanger. Further drop in domestic hot water temperature below 105°F (41°C) will activate the boiler.

## OPERATING EXPERIENCE

The completed system began operation in November 1980. During the remainder of the 80-81 heating season, the schools obtained all of their heat from the geothermal fluid. Only one business obtained geothermal heat during the first season. The following winter, the schools were heated entirely with geothermal energy except for a 2-hr period when supplemental heat was provided by the boiler. This occurred because the wind chill factor was -55°F (-48°C). Geothermal energy delivered to the school buildings during that heating season was 8.11 billion Btu (8.55 TJ). This displaced 10.5 billion Btu (11.1 TJ) of electricity, fuel oil and propane.

Eight more businesses were connected to the system for the 81-82 heating season and geothermal supplied 75 to 90% of their heating energy requirements.

Plugging of pipes at the water treatment plant has been a significant operating problem. Barium chloride was added to the water at a static mixer in the treatment building. Sulfate deposits partially plugged the mixer and pipe downstream of the mixer, and frequent cleaning was required. Installation of the current trough system for BaCl<sub>2</sub> addition and mixing has solved these problems.

Performance of the control system has been very satisfactory as far as the users are concerned. They have had reliable, economical heating. The operation has been unsatisfactory in terms of utilizing the resource efficiently. As operated, the school system extracts between 8 and 16°F (4 and 9°C) from the geothermal fluid, depending on load. This has been adequate to meet the schools needs; but, the flow rate is usually much higher than needed. In addition to inefficient use of the resource, barium chloride is wasted by treating the excess water. During a prolonged period of -35°F (-37°C) weather, the lowest temperature of the water reaching the disposal point was 128°F (53°C). It appears that the business district users are also somewhat inefficient in their use of the resource.

The remainder of the system has performed well. There have been no scaling or corrosion problems. This is attributed to the material selection being based on corrosion coupon tests with the actual geothermal fluid. The heat exchangers were opened and cleaned in May 1982. No evidence of corrosion or deposits were found on the geothermal side. Minor iron oxides deposits found on the domestic hot water side were believed to have been from the hot water storage tank. Annual inspection and cleaning should be more than adequate.

## ECONOMIC EVALUATION

Total capital costs for the Haakon geothermal system are estimated to be \$1,218,884. Expenditures through September 1983 were \$1,209,185. Future spending will cover system monitoring and a final report.

\$934,326 or 77% has been DOE money. Remaining funds were provided by the Haakon School District (\$213,669), businesses connected to the district heating system (\$52,110), and Brookhaven National Laboratory for a test of polymer concrete pipe in the system (\$9,080).

Total costs for the complete geothermal system were originally estimated to be \$438,763. Costs for the well, distribution system, and building conversion all exceeded estimates. Construction of a water treatment plant and district heating system added expenses that were not included in the original estimate.

Annual operating and maintenance costs for the entire system total nearly \$4,000. Annual energy displaced is about 123,000 kWh electricity, 55,000 gallons (208 m<sup>3</sup>) of fuel oil, and 24,000 gallons (91 m<sup>3</sup>) of propane.

Three factors had a significant impact on the cost of the project. The building retrofit costs were significant. Every room in each building had to be converted from steam heating, electrical resistance heating or propane to hot water heating.

The armory/high school boiler was obsolete and was replaced with new modular units. The boiler in the elementary school was modified to convert it from steam to hot water production.

The agreement between the school district and the business district is the second significant factor. The business district currently saves an estimated \$47,500 each year, but only pays \$2,500 to the school district.

Finally, the geothermal system could greatly increase its profitability by changing its operating philosophy. The school boilers could be used for peak heating during the severest weather. This would allow the school district to sell considerably more heat to the business district at very little additional cost to the school district.

It was observed that the school removes about 16°F (8.9°C) and the business district removes about 11°F (6.1 °C) from the peak flow rate of 340 gpm (21.5 L/s). This was under the extremely cold conditions -35°F (-37 °C) which occurred once in the last three years. The system was designed for a usable temperature drop of 32.35°F (17.97°C). Even at this extreme condition, only 83% of its design capacity was used.

## **CONCLUSIONS**

Equipment is readily available which will give reliable service in a geothermal environment. However, it should be carefully selected based on adequate corrosion testing.

The economics of the project would be much improved if: there had been no radium removal plant required, the retrofit would have been less expensive, the business district users had paid a larger percentage of their energy savings to the school district, and the school boilers were used for peaking to generate more revenue.

The control system should be adjusted to more fully utilize the resource particularly under partial load conditions. This may be difficult due to the redundancy and complexity of the present system. If necessary, the control system should be modified to make it more responsive to the varying heat demand. Conserving the resource should be a basic objective to assure its availability to a maximum number of future users. In addition, using the geothermal water more efficiently would reduce operating costs by using less barium chloride.

## **ACKNOWLEDGMENTS**

The authors would like to acknowledge the cooperation of Roland Smit and Reed Drury of Haakon School District No. 27-1, and Ray Hengel of Hengel, Lattimer & Associates in the preparation of this paper. The project was performed by the Haakon School District under DOE Cooperative Agreement No. DE-FC07-78ET27080, which was administered by the Department of Energy, Idaho Operations Office. Technical assistance was provided to the project by EG&G Idaho under DOE Contract No. DE-AC07-761001570.

The project was sponsored by the Department of Energy, Division of Geothermal and Hydropower Technologies, under the Program Opportunity Notice (PON) program.

## **EDITOR'S NOTE**

This article, which originally appeared in the *Geothermal Resources Council Transactions*, Vol. 7, October 1983, is reprinted in this condensed version with GRC's permission.

The original article reported nine buildings on-line in the downtown area; but, only eight are known today.