

DOWNHOLE HEAT EXCHANGERS

Gene Culver
John W. Lund
Geo-Heat Center

INTRODUCTION (Lund, et al., 1975)

The downhole heat exchanger (DHE) eliminates the problem of disposal of geothermal fluid, since only heat is taken from the well. The exchanger consists of a system of pipes or tubes suspended in the well through which "clean" secondary water is pumped or allowed to circulate by natural convection. These systems offer substantial economic savings over surface heat exchangers where a single-well system is adequate (typically less than 0.8 MWt, with well depths up to about 500 ft [150 m]) and may be economical under certain conditions at well depths to 1500 ft (450 m).

Several designs have proven successful; but, the most popular are a simple hairpin loop or multiple loops of iron pipe (similar to the tubes in a U-tube and shell exchanger) extending to near the well bottom (Figure 1). An experimental design consisting of multiple small tubes with "headers" at each end suspended just below the water surface appears to offer economic and heating capacity advantages.

In order to obtain maximum output, the well must be designed to have an open annulus between the wellbore and the casing, and perforations above and below the heat exchange surface. Natural convection circulates the water down inside the casing, through the lower perforations, up in the annulus and back inside the casing through the upper perforations. If the design parameters of bore diameter, casing diameter, heat exchanger length, tube diameter, number of loops, flow rate and inlet temperature are carefully selected, the velocity and mass flow of the natural convection in the well may approach those of a conventional shell-and-tube heat exchanger.

The interaction between the fluid in the aquifer and that in the well is not fully understood; but, it appears that outputs are higher where there is a high degree of mixing indicating that somewhat permeable formations are preferred.

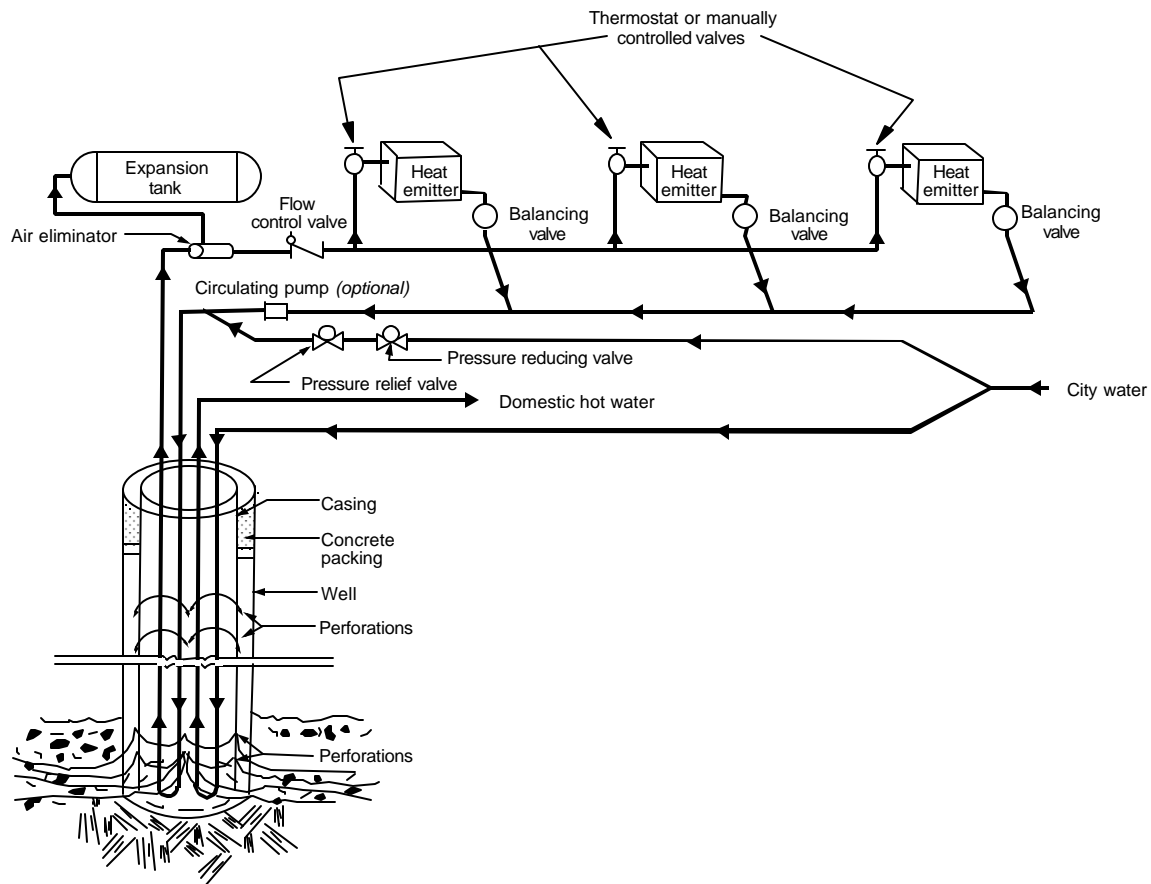

Figure 1. Typical downhole heat exchanger system (Klamath Falls, OR).

Considering life and replacement costs, materials should be selected to provide economical protection from corrosion. Attention must be given to the anodic-cathodic relationship between the exchanger and the casing since it is relatively expensive to replace the well casing. Experience in the approximately 600 downhole exchangers in use indicates that corrosion is most severe at the air-water interface at static water level and that stray electrical currents can accelerate corrosion. Insulating unions should be used to isolate the exchanger from stray currents in building and city water lines. Sealing the top of the casing to limit oxygen availability will also reduce the air-water interface corrosion.

DESIGN AND CONSTRUCTION DETAILS (Culver, 1987)

DHE outputs range from supplying domestic hot water for a single family from a 40-ft, 140°F (12-m, 60°C) well at Jemenez Springs, New Mexico, to over 1 MWt at Ponderosa Junior High School from a 560-ft, 202°F (170-m, 94°C) 16-in. diameter (40-cm) well in Klamath Falls, Oregon. DHEs are also in use in New Zealand, Turkey, Hungary, Iceland, Russia and other countries. A well producing 6 MWt has been reported in use in Turkey.

The wells in Klamath Falls are 10- or 12-in. (25- or 30-cm) diameter drilled 20 or more feet (6 m) into “live water” and an 8-in. (20-cm) casing is installed. A packer is placed around the casing below any cold water or unconsolidated rock, usually at depths of 20 - 50 ft (6 - 15 m), and the well cemented from the packer to the surface. The casing is torch perforated (1/2 in. x 6 in. [1 x 15 cm]) in the live water area and just below the lowest static water level. Perforated sections are usually 15 - 30 ft (4 - 9 m) long and the total cross-sectional area of the perforations should be at least one-and-a-half to two times the casing cross section. Since water levels fluctuate summer to winter, the upper perforations should start below the lowest expected level. A 3/4- or 1-in. (2- or 2.5-cm) diameter pipe welded to the casing and extended from surface to below the packer permits sounding and temperature measurements in the annulus and is very useful in diagnosing well problems.

“Live water” is locally described as a hot water aquifer with sufficient flow and permeability to wash away the fines produced in a cable-tool drilling operation or major lost circulation in rotary drilling.

The space heating DHE is usually 1-1/2- or 2-in. (4- or 5-cm) diameter black iron pipe with a return U at the bottom. The domestic water DHE is 3/4- or 1-in. (2- or 2.5-cm) diameter pipe. The return U usually has a 3 - 5 ft (1 - 2 m) section of pipe welded on the bottom to act as a trap for corrosion products that may fill the U preventing free circulation. Couplings should be malleable rather than cast to facilitate removal (Figure 2).

Other DHE types in use are short multiple tubes with headers at each end and straight pipes extending to near the well bottom with coils of copper or steel pipe at the ends. In Reno, Nevada, many DHE wells are pumped by small submersible pumps to induce hot water to flow into the well. Systems for use with heat pumps circulate refrigerant in DHE

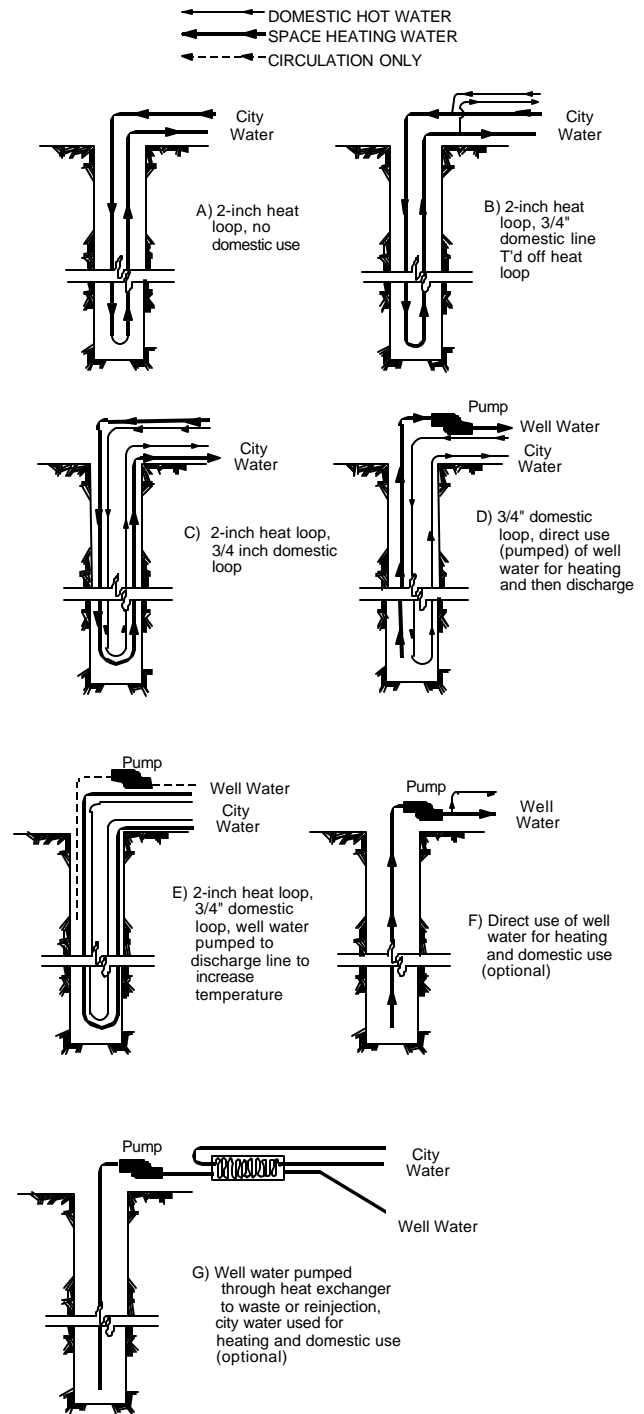

Figure 2. Downhole heat exchanger systems (Klamath Falls, OR).

pipes. A 20-kWt, 16-ft (5-m) prototype heat pipe system was successfully tested at least several months in the Agnano geothermal field in southern Italy (Figure 3)(Cannaviello, et al., 1982).

The first downhole heat exchanger, locally known as a coil, was installed in a geothermal well in Klamath Falls about 1930. The temperature of the well water and the predicated heat load determine the length of pipe required.

Based on experience, local heating system contractors estimate approximately 1 ft of coil per 1500 Btu per hr (1.4 kW/m) required as an average for the year. The “thermo-syphon” (or gravity feed in standard hot-water systems) process circulates the domestic water, picking up heat in the well and releasing the heat in the radiators. Circulation pumps are required in cooler wells or in larger systems to increase the flow rate. Thermo-syphon circulation will provide 3 - 5 psi (0.2 - 0.35 bar) pressure difference in the supply and return lines to circulate 15 - 25 gal/min (1 - 1.5 L/sec) with a 10 - 20°F (5 - 11°C) temperature change.

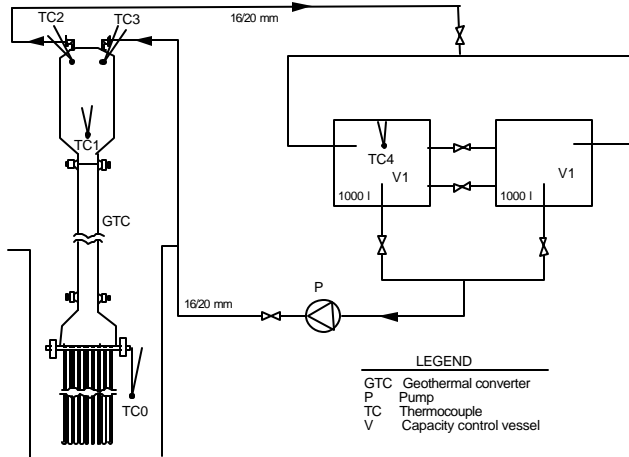

Figure 3. Experimental loop in Agnano, Italy.

There are several older or cooler wells that are pumped directly into the storm sewers or canal. In most cases, the well is pumped in order to increase the flow of geothermal waters and to raise the temperature of the well to a level locally considered satisfactory for use in space heating, about 140°F (60°C) (see Figure 2). In a few instances, mostly in the artesian area, well water is pumped directly through the heating system.

Considering life and replacement costs, materials should be selected to provide economical protection from corrosion. Attention must be given to the galvanic cell action between the groundwater and well casing since the casing is an expensive replacement. As indicated earlier, experience indicates that general corrosion is most severe at the air-water interface at the static water level and that stray electrical currents can cause extreme localized corrosion below the water. Insulated unions should be used at the wellhead to isolate the DHE from stray currents in the building and city water lines. Galvanized pipe is to be avoided since many geothermal water leach zinc and the anode-cathode relationship normally protecting steel in pipes reversed at 135°F (57°C) (Ellis, 1988).

Considerable success has been realized with non-metallic pipe, both fiberglass reinforced epoxy and polybutylene. Approximately 100,000 ft (30,000 m) of fiberglass reportedly has been installed in Reno at the bottom hole temperature up to 325°F (163°C). The oldest installations have been in about 10 years. The only problem noted has

been National Pipe Taper Threads (NPT) thread failure in some pipe that was attributed to poor quality resin. The manufacturer has warranted the pipe including labor costs.

Although the thermal conductivity for non-metallic pipes is much lower, the overall heat transfer coefficient is a combination of the pipe thermal conductivity, film coefficients, and conductivity of any scale or corrosion products on both sides. Since the non-metallic pipe is smooth, does not corrode and scale does not stick to it, the overall heat transfer can be nearly as good.

Average DHE life is difficult to predict. For the 500 or so black iron DHEs in Klamath Falls, average life has been estimated to be 14 years; however, in some instances, regular replacement in 3 - 5 years has been required (Lund, et al., 1975). In other cases, installations have been in service over 30 years with no problems. Stray electrical currents, as noted above, have undoubtedly been a contributing factor in some early failures. Currents of several tens of milliamps have been measured. In others, examination of DHEs after removal reveals long, deeply corroded lines along one side of the DHE. This may be due to continual thermal expansion and contraction while laying against the side of an uncased well. Constant movement would scrub off protective scale exposing clean surface for further corrosion.

Corrosion at the air-water interface is by far the most common cause of failure. Putting clean oil, preferably turbine oil (because of environmental acceptability) as is used in enclosed-tube lineshaft pumps, or paraffin in the well appears to help somewhat, but is difficult to accurately evaluate.

For some reason, DHE wells are typically left open at the top. There appears to be no good reason they could not be sealed air tight. Once the initial charge of oxygen was used up in forming corrosion products, there would be no more available since there is essentially no dissolved oxygen in the water. Closed wells appear to extend the life of the DHE (Swisher and Wright, 1990).

Convection Cells

Although the interaction between the water in the well, water in the aquifer, and the rock surrounding the well is poorly understood, it is known that the heat output can be significantly increased if a convection cell can be set up in the well. Also, there must be some degree of mixing (i.e., water from the aquifer) continuously entering the well, mixing the well water, and water leaving the well to the aquifer. There are two methods of inducing convection.

When a well is drilled in a competent formation and will stand open without casing, an undersized casing can be installed. If the casing is perforated just below the lowest static water level and the near the bottom or at the hot aquifer level, a convection cell is induced and the well becomes very nearly isothermal between the perforations (Figures 4 and 5). Cold surface water and unstable formations near the surface are cemented off above a packer. If a DHE is then installed and heat extracted, a convection cell, flowing down inside the casing and up in the annulus between the well wall and casing, is induced. The driving force is the density difference

between the water surrounding the DHE and water in the annulus. The more heat extracted, the higher the velocity. Velocities of 2 ft per second (0.6 m/s) have been measured with very high heat extraction rates; but, the usual velocities are between 0.04 and 0.4 ft per second (0.01 - 0.1 m/s).

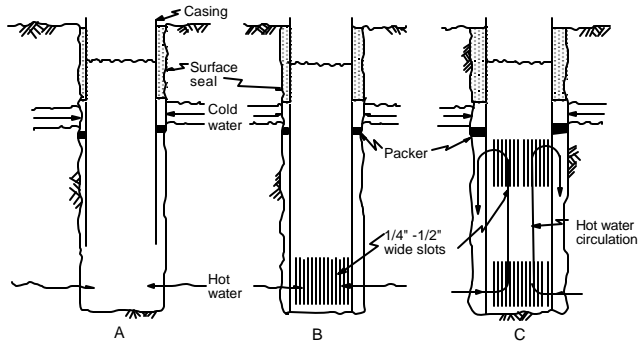

Figure 4. Well completion systems for downhole heat exchangers (type c preferred).

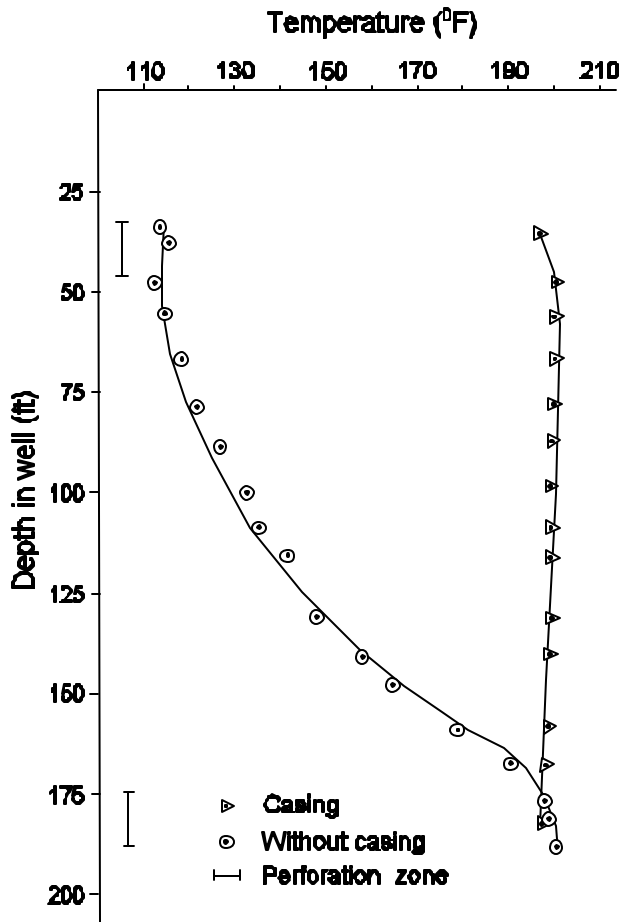

Figure 5. Temperatures vs. depth for a geothermal well (with and without perforations).

In Klamath Falls, it has been experimentally verified that when a well is drilled there is no flow in the wellbore. When the undersized perforated casing is installed, a convec-

tion cell is set up flowing up the inside of the casing and down the annulus between the casing and well wall. When a DHE is installed and heat is extracted, the convection cell reverses flowing down in the casing (around the DHE) and up the annulus. Similar circulation patterns were noted in New Zealand using convection promoters.

In New Zealand, where wells do not stand open and several layers of cold water must be cased off, a system using a convector promoter pipe was developed (Figure 6)(Allis and James, 1979). The convector pipe is simply a pipe open at both ends suspended in the well above the bottom and below the static water level. The DHE can be installed either in the convector or outside the convector, the latter being more economical since a smaller convector is used. Both lab and field tests indicate that the convection cell velocities are about the same in optimized designs and are similar to those measured in the undersized casing system. A summary of the New Zealand research is provided at the end of this section.

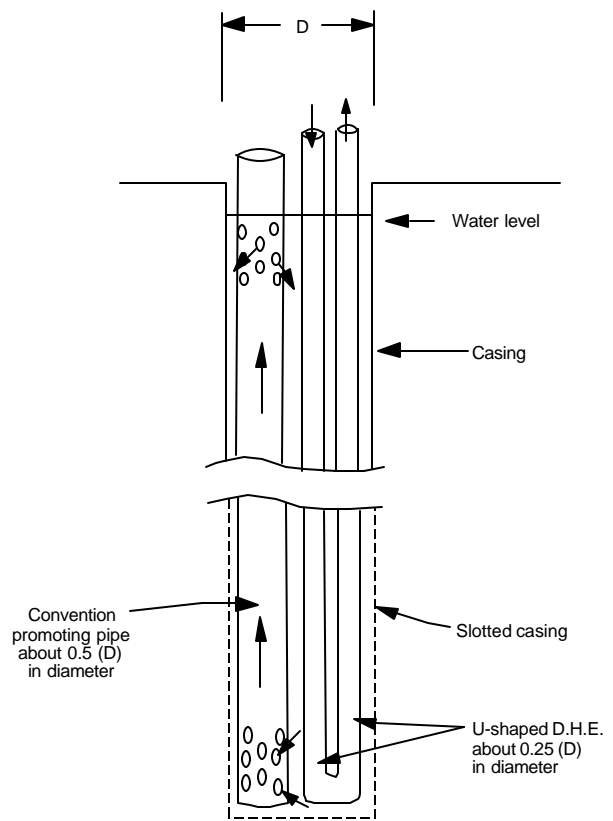

Figure 6. Convector promotion and DHE (New Zealand type).

Optimum conditions exist when frictional resistance due to wetted surfaces (hydraulic radius) is equal in both legs of the cell and DHE surface area providing maximum heat transfer. For the undersized casing and DHE inside the convector, this occurs when the casing or convector is 0.7 times the well diameter and 0.5 times the well diameter when the DHE is outside the convector. The full length U-Tube DHE is 0.25 times the well diameter in all cases. Partial length or multi-tube exchangers will have different ratios.

Maximum convection rates are obtained when the casing or convector pipe are insulated from each other. This maintains the temperature and density difference between the cell legs. Non-metallic pipe is preferred. Although corrosion products help insulate the pipe, scaling does not normally occur to any great degree since the casing or convector are the same temperature as the water.

Design Considerations

Downhole heat exchangers extract heat by two methods—extracting heat from water flowing through the aquifer and extracting stored heat from the rocks surrounding the well.

Once the DHE is extracting heat and a convection cell is established, a portion of the convecting water is new water entering the well—the same amount of cooled water leaves the well and enters the aquifer. The ratio of convecting water to new water has been termed the mixing ratio and is defined as:

$$RM = 1 - \frac{m_{add}}{m_{total}}$$

where:

- Rm = Mixing ratio
- m add = Mass flow of new water
- m total = Total mass flow of convecting water

Note that a larger number indicates a smaller proportion of new water in the convection cell.

Mixing ratios vary widely between wells in the same aquifer and apparently depend on aquifer permeability. Also, as more heat is extracted, the mass flow rate in the convection cell increases; but, the mixing ratio appears to remain relatively constant up to some point, then increases with further DHE loading. This is interpreted as permeability allowing “new” hot water to enter the well or, more probably, allowing “used” cool water to sink in to the aquifer near the well bottom. At some combination of density difference and permeability, the ability to conduct flow is exceeded and the well rapidly cools with increasing load.

The theoretical maximum steady-state amount of heat that could be extracted from the aquifer would be when the mixing ratio equals zero. That is, when all the water makes a single pass through the convection cell and out the well bottom. Mixing ratios lower than 0.5 have never been measured and usually range from about 0.5 - 0.94 indicating little mixing. The theoretical maximum steady-state can be estimated if one knows the hydraulic conductivity and hydraulic gradient, and assumes some temperature drop of the water.

If K is the hydraulic conductivity (coefficient of permeability) and \hat{h}/\hat{l} is the hydraulic gradient, by Darcy’s Law, the specific velocity through the aquifer is given by:

$$v = K \hat{h}/\hat{l}$$

The mass flow through an area, A, perpendicular to the flow is therefore:

$$vAd = KAd\hat{h}/\hat{l}$$

where d is the density of water. The steady-state heat flow can be found by:

$$Q = KAdc(T_o - T_i)\hat{h}/\hat{l}$$

where:

- A = Cross section of well in the aquifer or the perforated section
- d = Density of water
- c = Specific heat
- T_o = Aquifer temperature
- T₁ = Temperature of water returning to the aquifer

Multiplying the above by $Rm-1$, or about 0.4 to 0.5, one can determine the expected steady-state DHE output. The most important factor in the equation is K. This value can vary by many orders of magnitude—even in the same aquifer—depending on whether major fractures are intersected, drilling mud or debris partially clogs the aquifer, etc. The variation between aquifers can be even greater.

Based on short-term pump tests to determine hydraulic conductivity and an estimated 1% hydraulic gradient, the specific velocity in the Moana area of Reno is estimated at 1 to about 3 ft per year (0.3 - 1.0 m/yr)(Allis, 1981). The hot aquifer is generally encountered in mixed or inter-bedded layer of fine sand and silt stone. In Klamath Falls, on the other hand, where the hot aquifer is in highly fractured basalt and coarse cinders, specific velocity is estimated at 20 to 150 ft per day (6 to 46 m/day), perhaps higher in localized areas. Values of K in seven wells in Moana were estimated at 3×10^{-4} ft per second (1×10^{-7} meters per second). This implies a factor of 10 thousand to 10 million difference in the steady-state output. Indeed differences by a factor of 100 have been measured, and some wells in Moana have been abandoned because they could not provide enough heat even for domestic hot water.

Many DHE wells in Moana are pumped to increase hot water flow into the well. Pumping rates for residential use is limited to 1800 gallons per day (6800 L/day), and the pump is thermostatically controlled. This is designed to switch on the pump if the DHE temperature drops below some predetermined level, usually about 120°F (49°C). This method permits use of a well that would not supply enough heat using a DHE alone, yet minimizes pumped fluid and pumping costs. It is, however, limited to temperatures at which an economical submersible or other pump can be used.

Unfortunately, at the present time, there is no good design procedure. Culver and Reistad (1978) presented a computer program that appears to predict DHE output to within 10 - 15% if the mixing ratio is known. The problem is, there is no way of predicting mixing ratio except by experi-

ence in a specific aquifer and then probably only over a fairly wide range as noted above. The procedure was written in FORTRAN, but has been converted to HP-85 BASIC by Pan (1983), and later modified by Lienau and Culver as documented in Culver, 1990. The program enables optimum geometric parameters to be chosen to match a DHE to a load if one assumes a mixing ratio.

The program does not include a permeability variable nor does it take thermal storage into account. In wells with good permeability, thermal storage may not be a significant factor. Experience in Reno indicates that for low-permeability wells, thermal storage is very important and that with low permeability, a convection promoter can promote thermal storage and, thereby, increase non-steady-state output.

Permeability can be rather accurately estimated with relatively simple Hvorslev plots used in well testing. Relating the permeability thus obtained to mixing ratios typical in other permeabilities, could give an estimate of the mixing ratio one could use in the computer program. The problem is, there seems to be no middle ground data available, only very high and very low permeabilities, and precious little of that.

NEW ZEALAND EXPERIENCE WITH DOWNHOLE HEAT EXCHANGERS

Early Work by R. G. Allis and R. James (Allis and James, 1979)

The research of Allis and James was into the use of domestic wells, which were used for low-grade direct heating, and potentially powerful steam-water wells, which often had relatively cool water over most of their depth. Thermal convection was inhibited by the large aspect ratio (length to diameter ratio) of the well. The domestic wells could not use the Klamath Falls type downhole heat exchanger since the well had already been cased without perforations, and thus, heat could only be extracted over a very short length near the bottom. In a similar manner, deep high-temperature geothermal wells are sometimes difficult to discharge because of the great depth of cool water overlying the hot zone.

In their laboratory research, they found that, if a pipe (promoter) is inserted into their model of a well, natural convection will occur and the hot water will flow to the top of the well (Figure 7). The diameter of the pipe determined whether the hot water would flow up the pipe and down the annulus, or the reverse. The promoter pipe should at least be slotted on the lower end, especially if it rests on the bottom of the well.

The research also found that in domestic wells, the promoter pipe improved heat output by 60 to 120%, depending upon the diameter. The DHE in the annulus gave higher heat output from the DHE than if placed inside the promoter (Figures 8 and 9). The maximum flow (vertical) in the well occurs when the frictional pressure-drop in the promoter pipe equals that of the annulus. Thus, the promoter

pipe should equal 0.5 the well diameter if the DHE is placed in the annulus and, should equal 0.7 the well diameter if placed inside the promoter. The DHE pipe should be 0.25 the well diameter (Figure 7). Using these recommended dimensions, the quantity of thermal energy available to the DHE is limited mainly by the existing bottom hole permeability. If the temperature of the well water is less than boiling (100°C), then stiff plastic pipe can be used since it is a poor thermal conductor, and is also comparatively smooth.

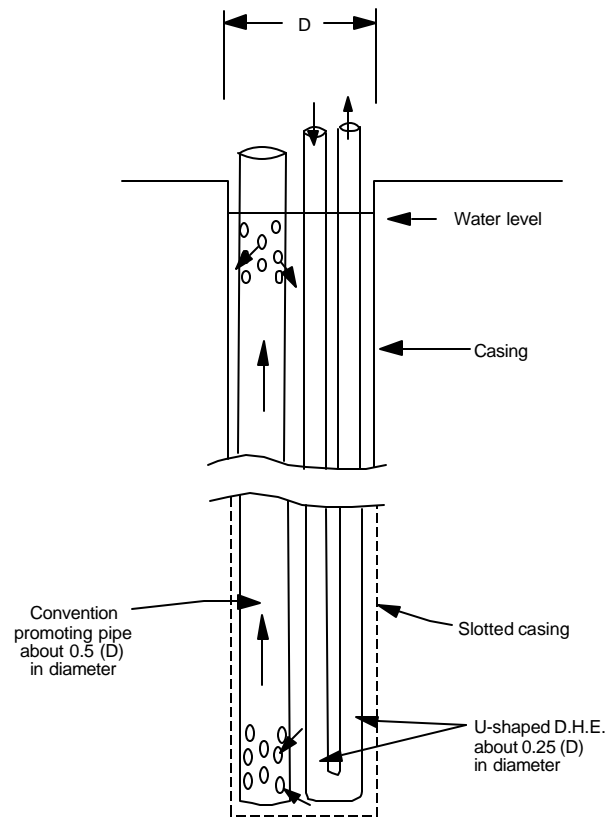

Figure 7. Scheme for optimizing the heat output of a DHE.

For potentially powerful (high-temperature) geothermal wells which are difficult to discharge, a 2-in. (5-cm) diameter pipe, positioned beneath the water level (Figure 10), should raise wellhead pressure (by promoting internal convection) to the point where controlled, spontaneous discharge is possible. This promoter pipe is placed approximately 160 ft (50 m) below the water surface and is slotted on both ends. Once the wellhead valve is opened and production conditions exist, the pipe should only slightly restrict vertical mass discharge which takes place both in the annulus and in the pipe.

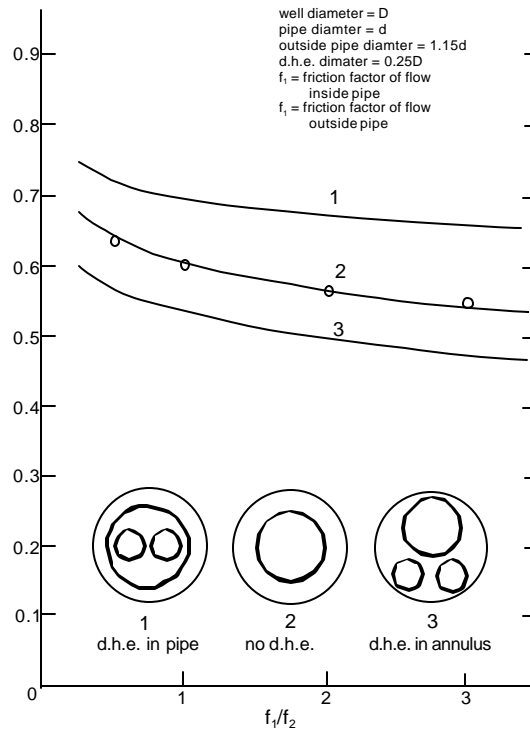

Figure 8. Optimum diameter of the convection promoting pipe for varying friction factor ratio; in the three cross-sections, $f_2/f_1 = 2$. Refer to text for derivation of the 4 points and the curves.

This method of stimulating vertical convection, and thus promoting uniform high temperature throughout the well column, is preferred instead of using a downhole pump or airlifting with the associated environmental problems of fluid disposal.

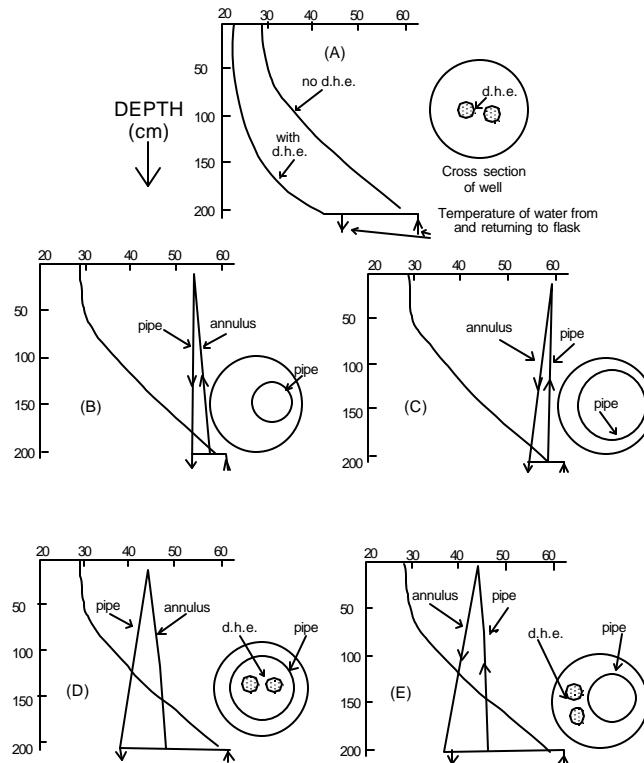

Figure 9. Characteristic temperature and flow regimes observed in a laboratory model of a well; configuration of convection promoting pipe and/or DHE is shown in the cross-section in each case.

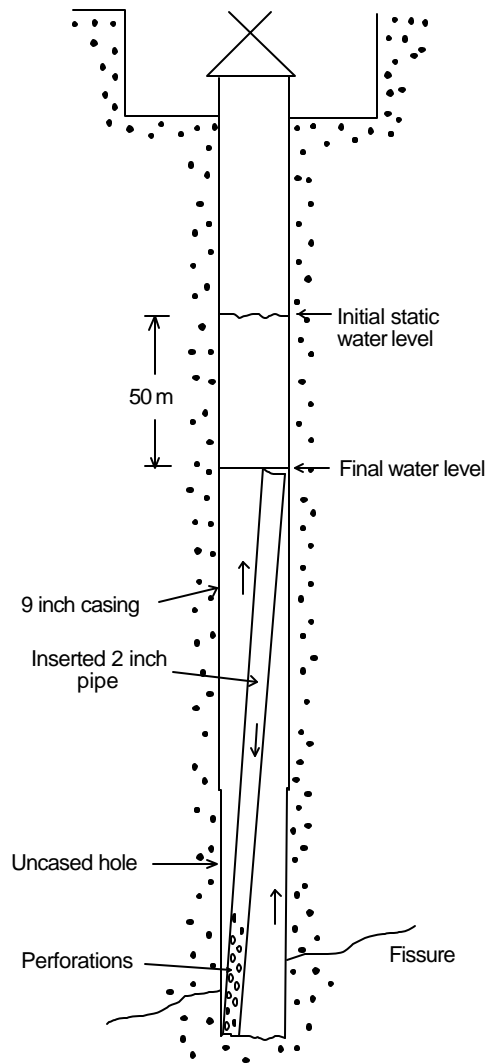

Figure 10. Scheme for promoting convection in a geothermal power well.

Experimental Work at the University of Auckland (Freeston and Pan, 1983)

The investigations of Freeston and Pan are based on both laboratory and field work in the Taupo area of New Zealand, and using results of work in the Moana area of Reno, Nevada (Allis, 1981). They looked at the heat transfer and flow mechanisms in the vertical convection cell of wells with DHEs. Conclusions were drawn from computer analysis and subsequent field testing. The work by Allis (1981) showed that in order to obtain 10 kW continuously for 24 hours (peak of 20 to 30 kW) from a DHE to supply a household from a 20-cm diameter well, 50-m deep in a reservoir where the hydraulic gradient was 1%, a permeability of about 50 darcies (5×10^{-4} m/s) is necessary. Above 50 darcies, a promoter can be utilized; below, a small pump will be necessary. However, Allis did note that in wells with permeability below 50 darcies, the stored heat in the form of hot rock adjacent to the well may provide sufficient heat for days or even weeks. However, in the long-term, the well will cool off. The use of a convector pipe will not improve the long-term output of the DHE. A

convector pipe only keeps the well water mixed and does not draw in fresh hot water. As mentioned above, these wells require some form of pumping to induce the required heat flow.

Based on their work and that of Allis, it was concluded that convective (vertical) flow must be favored instead of conductive (horizontal) flow between the promoters and the annulus, in order to maximize the output of DHEs. The relationship that best defined these conditions is:

$$D^0/L$$

where:

- D^0 = Diameter of the promoter pipe in cm
- L = Length of the pipe in m

For $D^0/L < 1$, then conductive heat flow dominates.

For $D^0/L > 1$, then convective heat flow dominates.

Since heat flow should be convective, (1) long and small diameter promoters should be avoided as they do not generate significant circulation of the well fluid, and (2) it is best to have promoters with as large a diameter as possible, and use a low-conductivity material to get maximum vertical convection.

Field Work in Rotorua (Dunstall and Freeston, 1990)

A series of tests were conducted on a U-Tube DHE installed in a 100-mm diameter well which previously provided a steam/water mixture to heat a building in Rotorua. The field work was conducted to study the fluid temperatures inside the heat exchanger tubes resulting in a better understanding of the heat transfer processes involved in a typical Rotorua DHE/well system.

The DHE/well system consisted of a 123-m deep well cased to 112 meters with a bottom hole temperature of 160°C. A 25-mm diameter U-Tube produced a maximum output of 150 kW. The standing vs. DHE running (in operation) temperature profile of the well is shown in Figure 11.

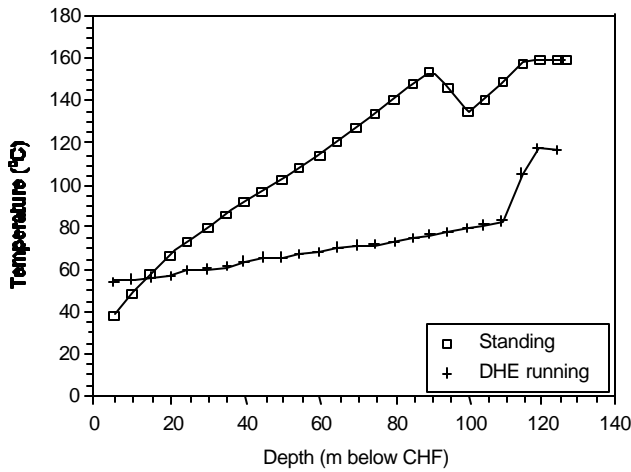

Figure 11. Downhole temperature.

The results of the test showed that the temperature increased below the uncased portion and thus, almost all heat exchange occurred at the feed zone. In the cased portion, heat was lost to the return leg (cold leg) of the DHE from the supply leg (hot leg) (Figure 12).

In order to prevent this heat loss, they recommended that either (1) the return leg from the casing bottom to the surface be insulated, or (2) that a smaller diameter return pipe be used, thus producing higher velocities inside it resulting in less heat loss.

The flow rate in the DHE was also varied from just above 0.4 L/s to 1.2 L/s (Figure 13). As was expected, the heat output in kW increased with flow rate; however, the typical output curve will flatten as flow rates become “high” (Figure 14). At “high” flow rates, the return temperature has a tendency to fall off, negating some of the gain, and pumping costs also increase. The likely increase in heat output would probably more than cover the increase pumping cost for moderate increases in flow rate. They concluded that the use of promoters would greatly enhance the well heat output.

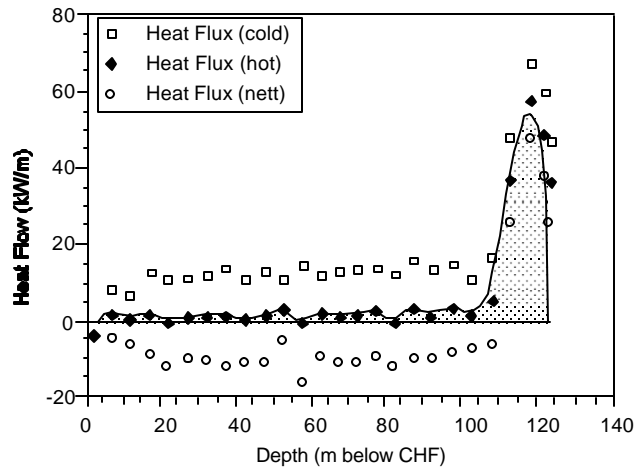

Figure 12. Heat flux (1.2 l/s).

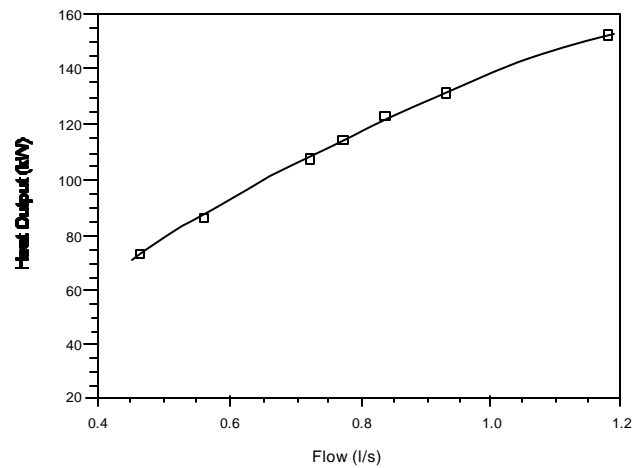

Figure 13. Heat output vs. flow rate.

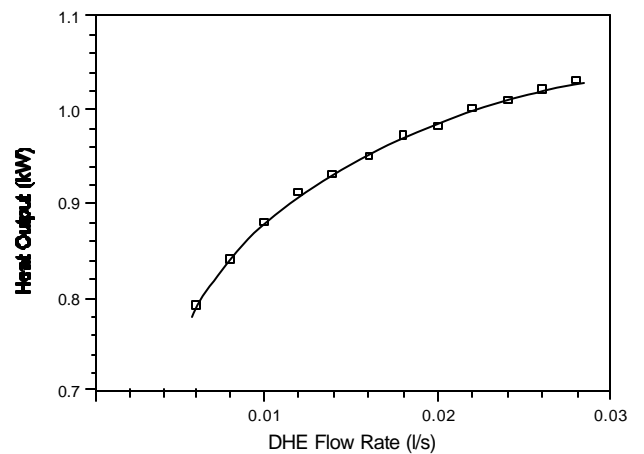

Figure 14. Typical output curve for a DHE (taken from numerical data by Pan, 1983).

Two different materials, copper and PVC, were used to construct two identical U-Tube DHEs, which were tested over a range of DHE flow and well aquifer cross-flow rates.

During most tests, a PVC convection promoter pipe was fitted in the well, to allow a bulk circulation of the well fluid. Various combinations of the DHE pipes inside and outside the promoter pipe were investigated. Some comparisons were made to results obtained during full-scale testing in a shallow Rotorua well.

The basic conclusion, as found by others, was that the output from the DHE increased with increasing cross flow in the aquifer at the well bottom and with increasing DHE flow rates. Both relationships appear nearly linear at low flow rates; but, the performance improvement tapers off as the flow rate increases (as was seen in the work by previous work by others discussed earlier). In larger diameter wells, the DHE supply (hot leg) temperature was less than the well temperature; therefore, there was no heat loss by conduction.

When a promoter pipe was installed, the bulk well circulation can be obtained in either a forward or reverse direction (Figure 15), with the forward direction (up the annulus and down inside the promoter pipe) yielding a higher heat output of the DHE by 10 to 20% (Figures 16 and 17). Thus, they recommended that the DHE return (cold) leg be placed inside the promoter pipe with the supply (hot) leg in the annulus to produce forward flow. Otherwise, forward flow may have to be stimulated by use of an airlift pump. It was also found that the heat output of the PVC DHE is quite high compared to the copper DHE, considering its thermal conductivity. This was due to the low percentage of the total

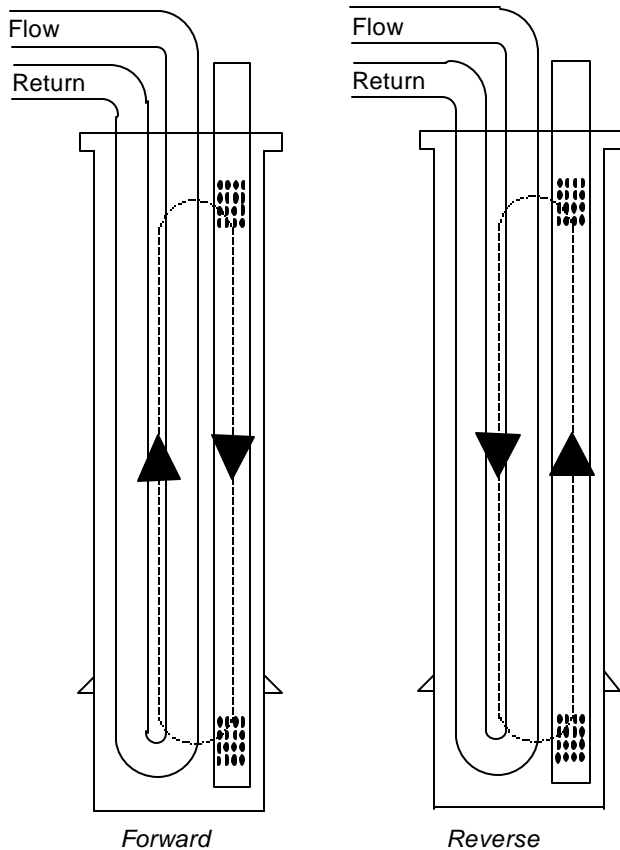

Figure 15. Circulation flow directions.

heat transfer resistance represented by the tube and the face that no heat was lost in the return leg. Thus, they recommended that a hybrid DHE consisting of a copper supply and a PVC return leg be used to provide higher heat transfer rates, as compared to either of the single material DHEs

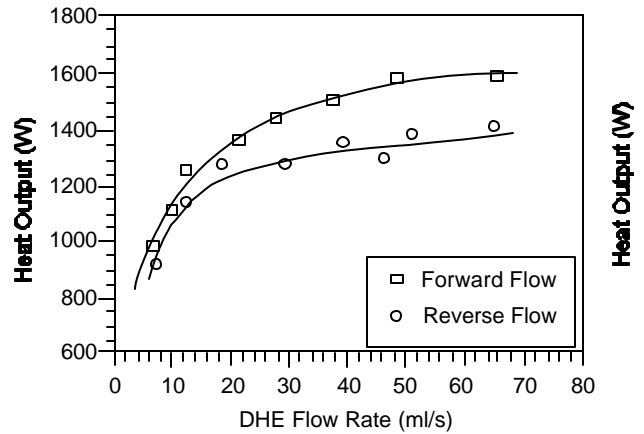

Figure 16. Heat output vs. DHE flow (32-mm promoter)(Cross-flow rate 25.8 ml/s).

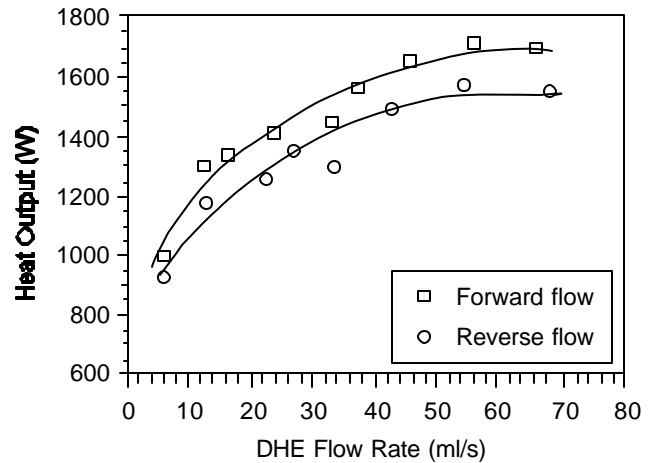

Figure 17. Heat output vs. DHE flow (32-mm promoter)(Cross-flow rate 31.4 ml/s).

REFERENCES

Allis, R. G., 1981. *A Study of the Use of Downhole Heat Exchangers in the Moana Hot Water Area, Reno, Nevada.* Geo-Heat Center, Klamath Falls, OR.

Allis, R. G. and R. James, 1979. *A Natural Convection Promoter for Geothermal Wells.* Geo-Heat Center, Klamath Falls, OR.

- Cannaviello, M.; Carotenuto, A. C.; Reale, F.; Casarosa, C.; Latrofa, E. and L. Martorano, 1982. "An Advanced System for Heat Transfer from Geothermal Low- and Medium-Enthalpy Sources." *Papers presented at the International Conference on Geothermal Energy, Florence, Italy*, Vol. 2, pp. 63-80.
- Culver, G. G., 1987. *Draft Report*. Geo-Heat Center, Klamath Falls, OR.
- Culver, G. G., 1990. *DHE*. Report prepared for USDOE, Geo-Heat Center, Klamath Falls, OR.
- Dunstall, M. G. and D. H. Freeston, 1990. "U-Tube Downhole Heat Exchanger Performance in a 4-Inch Well, Rotorua, New Zealand." *Proceedings of the 12th New Zealand Geothermal Workshop*, pp. 229-232.
- Ellis, P. F. and M. F. Conover, 1981. *Materials Selection Guidelines for Geothermal Energy Utilization Systems*. Radian Corporation, Austin, TX.
- Freeston, D. H. and H. Pan, 1983. "Downhole Heat Exchanger." *Proceedings of the 5th New Zealand Geothermal Workshop*, pp. 203-208.
- Hailer, S. and M. G. Dunstall, 1992. "Downhole Heat Exchanger Experiments in a Laboratory Scale-Model Well." *Proceedings of the 14th New Zealand Geothermal Workshop*, pp. 93-98.
- Lund, J. W.; Culver, G. G. and L. S. Svanevik, 1975. "Utilization of Intermediate-Temperature Geothermal Water in Klamath Falls, Oregon." *Proceedings of the 2nd U.N. Symposium in the Development and Use of Geothermal Resources, San Francisco, CA*, Vol. 2, p. 2147-2154.
- Pan, H., 1983. Master's Thesis. University of Auckland, New Zealand, Department of Mechanical Engineering.
- Swisher, R. and G. A. Wright, 1990. "Inhibition of Corrosion at the Air-Water Interface in Geothermal Downhole Heat Exchangers." *Geo-Heat Center Quarterly Bulletin*, Vol. 12, No. 2, pp. 10-13.