

INTEGRATING SMALL POWER PLANTS INTO DIRECT-USE PROJECTS

Dr. R. Gordon Bloomquist, Ph.D.,
Washington State University Energy Program

INTRODUCTION

Although generation of power from geothermal energy with small “wellhead generators” (i.e., units <5MWe) is not new, the past few years have seen an increased interest, application and research into this technology (see *GHC Bulletin*, Vol. 20, No. 2, 1999). As a result, there has been a considerable amount of work done on various working fluids including various Freon, organic fluids (e.g., propane, isobutene, etc.), ammonia, and interest and research into low-temperature flash is also on the rise.

Some existing units have now seen over 20 years of operation and although most earlier units were put online as stand alone plants, or as the first step in demonstrating the viability of a field prior to build out, recent work has been directed toward the development of combined heat and power projects that couple power production with direct-use applications. Recent projects in Austria, including the Rogner Hotel and Spa Eco-Resort in Bluman (Figure 1) and the geothermal district heating project in Altheim (Schochet and Legmann, 2002; Gaia 2002) are excellent examples of integrated projects designed to both provide power and supply space heating (see article in this *Bulletin*).

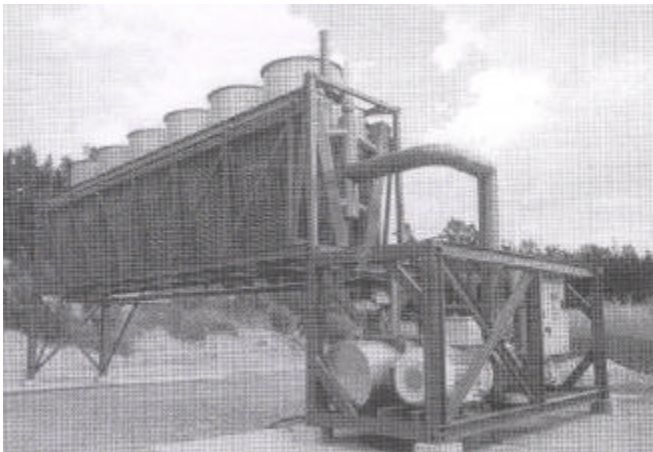

Figure 1. *Series 250 ORMAT Energy Converter Power Unit at Bad Blumau (Schochet & Legmann, 2002).*

One of the most interesting recent developments in the use of small wellhead-type generation is the coupling of such systems to agribusiness (e.g., agriculture crop dehydration, alcohol distillation, greenhouses and aquaculture).

HISTORY

The advent of small power plants dates to the very beginning of geothermal power production. The first plant

dates back to 1904 when Prince Piero Ginori Conti first used geothermal energy to power 10-kWe reciprocating engine to drive a small generator in order to provide lighting to his boric acid factory in Larderello, Italy (Lund, 2004).

The first commercially produced geothermal power was also generated at Larderello; when in 1914, a 250-kWe unit began providing power to the cities of Volterra and Pomarance.

In the early-1900s, the first small geothermal power plant in the United States went online at The Geysers in northern California. This 35-kWe unit provided power to the local resort, and a few, if any, could imagine at the time that The Geysers geothermal field would someday be the largest producer of geothermal power in the world.

In 1967, an experimental binary power plant was commissioned at Paratunka, Kamchatka, Russia (Lund and Boyd, 1999). This small 680-kWe power plant used 81°C (178°F) geothermal water and although it is considered to be one of the earliest binary power plants, it is interesting to note that the first commercial geothermal power plant at Larderello were also, in fact, binary-type plants. At Larderello, the geothermal steam was used to evaporate clean water to power steam turbines; thus, avoiding the corrosion effects related to the use of the geothermal steam directly (DiPippo, 1999).

By the early-to-mid 1980s, small binary plants had been demonstrated to be economically viable in a number of locations and by the mid-1990s, commercial plants were located throughout the western U.S., and throughout much of the world. Small flash plants have also proved their commercial viability and can be found in such diverse countries as Iceland, Mexico, Japan, Portugal (Azores) and Ethiopia to name but a few (Lund and Boyd, 1999).

TECHNOLOGIES

The vast majority of small geothermal power plants are either binary or flash; although, some are a hybrid of both, and even dry steam has been used in at least one application. Both flash steam and binary technologies have their own proponents, and each has its own set of advantages and disadvantages.

Flash Steam Plants

In a flash steam plant (either single or double flash), the two-phase flow from the well is directed to a steam separator; where, the steam is separated from the water phase and directed to the inlet to the turbine. The water phase is either used for heat input to a binary system in a direct-use application, or injected directly back into the reservoir (Figure 2).

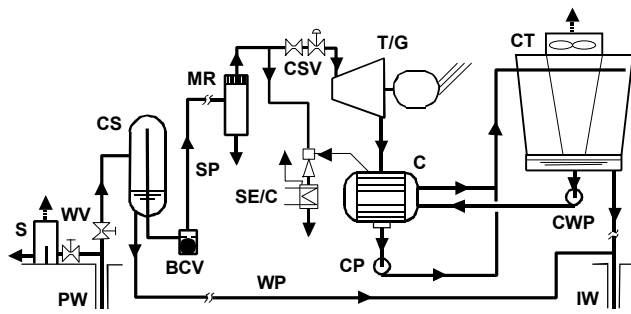

Figure 2. *Simplified flow diagram for a single-flash geothermal power plant (DiPippo, 1999).*

The steam, after passing through the turbine, exits into the condenser; where, it is cooled via water from the cooling tower. Historically, flash has been employed where resource temperatures are in excess of approximately 150°C (300°F); however, studies completed by Barber Nichols Inc. of Arvada, Colorado (Forsha, 1994) would seem to indicate that flash technology could be employed at temperatures as low as 120°C (250°C) or less, and at a cost significantly lower than that of a similarly sized binary plant. Cost savings are attributable to cost differences in the heat addition and heat rejection systems of the two competing technologies. Examples of small flash plants can be found in, for example, Japan and Guadalupe.

In Japan, a small flash facility was installed at the Kirishima International Hotel in Beppu, Kyushu in 1983. The 100-kWe non-condensing unit operates on the output of two production wells and has an inlet temperature of 127°C (261°F) at 2.45 bar (35.5 psi). Electricity is used for base load in the hotel and provides 30-60% of the load depending upon season and time of day. Hot water from the separator is used for outdoor bathing, space heating and cooling, domestic hot water heating of a sauna bath, and for two indoor baths (Lund and Boyd, 1999).

On the Island of Guadalupe, the Bouillante geothermal flash condensing power plant was put online in 1986 with the plant being modernized and several improvements made in 1995 and 1996 (Correia, et al., 1998). Improvements included installation of three automated controllers to monitor all plant activity and manage operations. The plant is a double-flash plant based on a geothermal resource of approximately 200°C (392°F). Steam pressure from the two separators are six and one bar (87 and 15 psi), respectively. Cooling is through the use of seawater in a direct-contact heat exchanger.

Binary Plants

In a binary plant (Figure 3), the thermal energy of the geothermal fluid is transferred to a secondary working fluid via a heat exchanger to use in a conventional Rankine Cycle, or alternatively Kalina Cycle (Figure 4). The vaporized working fluid (e.g., isopentane, propane, Freon or ammonia) drives the turbine before being condensed and returned to the heat exchanger in a closed loop. Cooling is generally provided through the use of air coolers; although, some work

on evaporatively enhanced air cooling is ongoing (Sullivan, 2001) and could result in efficiency improvements of 5% or more during summer periods.

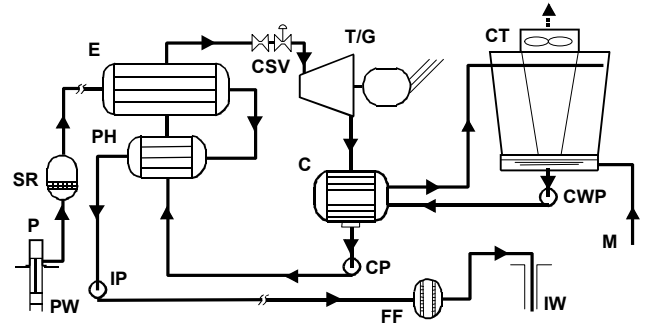

Figure 3. *Simplified flow diagram for a basic binary geothermal power plant (DiPippo, 1999).*

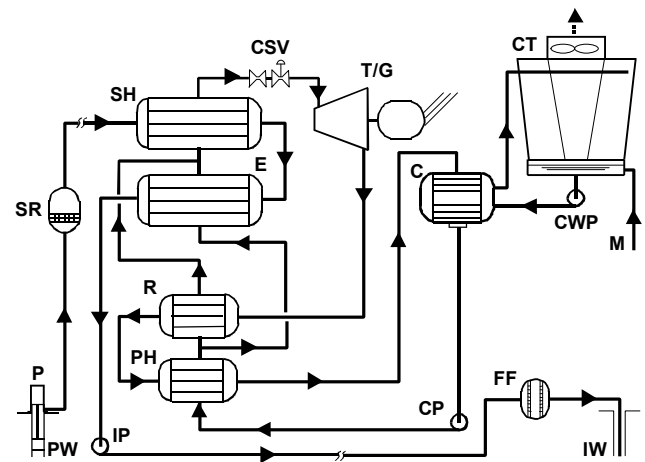

Figure 4. *Simplified flow diagram for a Kalina binary geothermal power plant (DiPippo, 1999).*

Examples of small binary plants are found, for example, in the United States and Austria. The Wineagle and Amedee power plants are located near the shore of Honey Lake in northern California. The Wineagle power plant went online in 1985, and consists of two binary units of total gross output of 750-kWe and a net output of 600-kWe. The Amedee plant is composed of two units of one-MWe each and has a net output of 1.5 MWe. Resource temperatures are relatively low, 110°C (230°F) at Wineagle and 104°C (219°F) at the Amedee plant, and flow rates are 63 L/s (1000 gpm) and 202 L/s (3200 gpm), respectively. The plants were designed to operate on Freon 114, but since then, the Wineagle plant has been converted to operate on isobutene (Nichols, 2003). Both plants have operated with an availability of over 90% and a capacity factor that has at times exceeded 100% of name plate. The plants are fully automated and are designed to operate unmanned and to go through a self-start procedure if tripped off line due to a transmission line failure. The plants can be monitored and started remotely if required.

The Altheim, Austria binary plant is a 1-MWe net output facility designed to operate on 86 L/s (1360 gpm) of 106°C (223°F) geothermal water. The plant is water cooled. The plant uses a special high molecular mass organic compound as the working fluid. According to Gaia (2002), the working fluid is non-flammable, non-corrosive and has no ozone depletion activity. The turbine uses variable geometry nozzles that were specifically designed to maintain high efficiency at partial load, and the nozzles variable geometry allows the turbine to be adapted to meet various geothermal and cooling water flow rates. The unit includes a programmable logic controller that allows for remote monitoring and control, with the only exception being during startup. The outlet temperature of the geothermal fluid from the unit is 70°C (158°F) and is used to provide heat to the Altheim district heating system.

GEOTHERMAL POWER GENERATION AND AGRIBUSINESS INDUSTRIES

The development of agribusiness/power projects has become one of the fastest growing areas of interest for low-temperature geothermal development (i.e., <150°C [300°F]). As early as the beginning of the 1980s, however, the first agribusiness/power plant project was initiated in Nevada at Wabusca. The project consists of an alcohol distillation plant and two small <1-MWe Organic Rankine Cycle generators. Cooling was provided through the use of a spray cooling pond. Unfortunately, the alcohol distillation facility was shut down shortly after it went into production due to a lack of feed stock. The power plant has continued in operation, and despite the premature demise of the distillation plant, proved the viability of the concept.

In the spring of 2000, the National Renewable Energy Laboratory (NREL) issued a request for the construction of small-scale (300-kWe to 1-MWe) geothermal power projects and five projects were selected for funding. Of these, three have reached agreements with NREL and projects are going through preliminary stages of design. The purpose of the program is to better establish the economic viability of small power plants through documentation of capital cost, system performance, and operation and maintenance requirements over a three-year test period in different regions of the United States. All three of the projects incorporate power production into already existing agriculture facilities. The three projects are Empire Energy in Empire, Nevada; Milgro - Newcastle in Newcastle, Utah and AmeriCulture near Cotton City, New Mexico (Kutscher, 2001).

AmeriCulture

The AmeriCulture project involves the design, installation, operation and monitoring of a 1.42-MWe gross (abt. 1-MWe net) water-cooled Kalina Cycle geothermal power plant using ammonia-water as the working fluid. The project is located near Cotton City, New Mexico, south of Lordsburg.

The plant (Figure 5) will supply electricity to the AmeriCulture fish hatchery. Geothermal fluid will be pro-

vided from an existing 120-m (400-ft) production well producing approximately 63.1 L/s (1000 gpm) of approximately 115-120°C (240-250°F) brine from the Lightning Dock geothermal resource. The “waste heat” from the power plant will be used to heat tanks used for the rearing of tilapia for sale to aquaculture farms that raise the tilapia for market. The estimated cost of the project is \$3,370,000 (Kutcher, 2001).

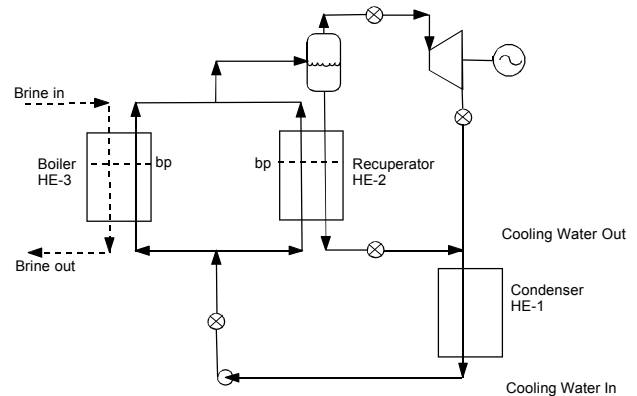

Figure 5. Energy/AmeriCulture Kalina Cycle schematic (Kutscher, 2001).

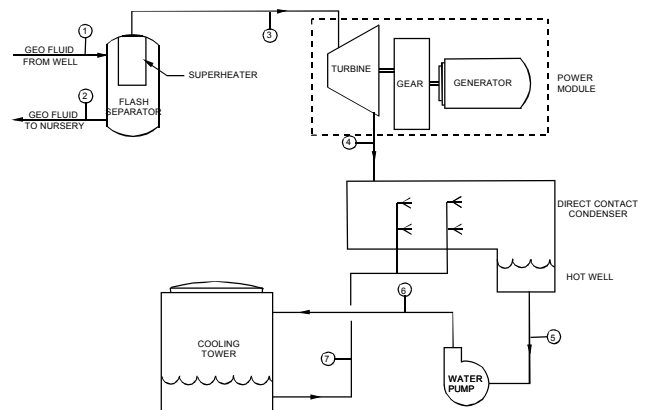

Figure 6. Milgro-Newcastle low-pressure flash system schematic (Kutscher, 2001).

Milgro-Newcastle

The Milgro-Newcastle project is located some 240 km (150 miles) northeast of Las Vegas, Nevada, in Newcastle, Utah. The plant (Figure 6) is being designed as a low-pressure flash plant based on the estimated 135°C (275°F) geothermal resource widely available in the Escalante Valley. The 1-MWe gross plant will deliver approximately 705 kWe net to the Milgro nursery. The separated brine at about 92.5°C (198.5°F) will provide heat to the greenhouse complex at the Milgro nursery. The estimated total cost of the project is \$2,550,000 and includes \$400,000 for well development (Kutscher, 2001).

Empire Energy

The Empire project began in 1987 as a small power project built as a partnership between ORMAT and Constellation Energy. The initial project was based on an approximately 130°C+ (266°F+) resource and generated about 3.6 MWe (Figure 7).



Figure 7. Binary power plant in Empire, Nevada.

In 1994, Empire Farms built an onion and garlic dehydration plant (Figure 8). The dehydration plant is capable of drying approximately 40,000 tons of product per year. In 1997, Empire Energy, a subsidiary of Empire Farms took over the initial power plant and wells drilled for the dehydration plant began supplying the power plant in addition to meeting the requirements for dehydration.



Figure 8. Onion and garlic dehydration plant.

The new wells produced geothermal fluids at approximately 147°C (297°F) from between 500-650 m (1640-2130 ft) depth.

The proposed new facility (Figure 9) is being designed to use water cascaded from the dehydration plant at about 120°C (250°F) flow of approximately 75 L/s (1190 gpm).

The plant is being designed to produce a minimum of 1.2 MWe for sale to Empire Foods, L.L.C. The plant had originally been designed to demonstrate the benefits of

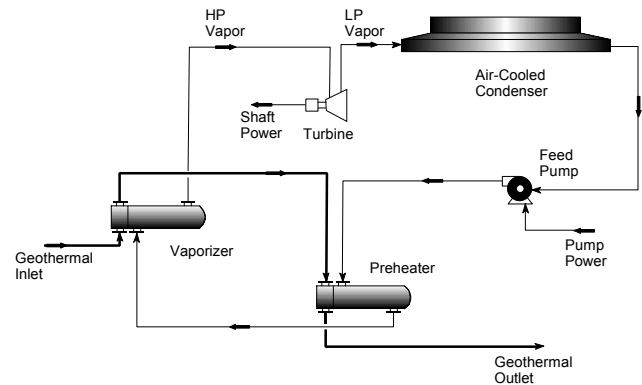

Figure 9. Empire Energy binary-cycle system schematic (Kutscher, 2001).

evaporatively enhanced dry cooling, but because this has already been successfully demonstrated at a plant in California (Sullivan, 2001), the decision was made to revise the design to incorporate variable concentrations of mixed working fluids to best achieve optimum operational efficiency and to use water cooling (Green, 2003).

The estimated total cost of the project was initially \$2,555,000 (Kutscher, 2001). This cost is at present being recalculated, taking into account the modification in design noted above. This will be an extremely interesting project to follow, as unlike the design of most agribusiness/power plant projects, the Empire project will use water cascaded from the dehydration plant rather than using the highest temperature resource for power production (i.e., a bottoming cycle).

SUMMARY

The integration of power production and agribusiness projects can significantly improve the economic viability of using lower temperature geothermal fluids and can result in a much higher overall “fuel use efficiency” than can be achieved with stand-alone power or direct-use projects. Validation of the economic, performance, and operation and maintenance requirements of these facilities should be a major step in encouraging the replication of such projects worldwide.

NOMENCLATURE FOR PLANT FLOW DIAGRAMS (Figures 2, 3 and 4)

BCV - ball check valve	C - condenser
CP - condensate pump	CS - cyclone separator
CSV - control and stop valve	CT - cooling tower
CW - cooling water	CWP - cooling water pump
E - evaporator	F - flasher
FF - final filter	IP - injection pump
IW - injection wells	M - make-up water
MR - moisture remover	P - well pump
PH - preheater	S - silencer
SE/C - steam ejector/condenser	SH - superheater
SP - steam piping	SR - sand remover
T/G = turbine/generator	TV - throttle valve
WP - water piping	WV - wellhead valves

ACKNOWLEDGMENT

This paper is a edited version of a paper presented at the European Geothermal Conference 2003 in Szeged, Hungary, May 2003.

REFERENCES

- Correcia, H.; LeNir, M. and L. M. Rochat, 1998. Automatisation and Environmental Integration of 5-MW Power Plant in Guadalupe, "Conditions of Extension of Power Generator," Proceedings of the International Summer School in the Azores, Skopje, Macedonia, Chapter 10.
- DiPippo, R., 1999. "Small Geothermal Power Plants: Design, Performance and Economics." *Geo-Heat Center Quarterly Bulletin*, Vol. 20, No. 2, pp. 1-8.
- Forsha, M., 1994. "Low-Temperature Geothermal Flash Steam Plants." *Geothermal Resources Council Transactions*, Vol. 18, pp. 515-522.
- Gaia, M., 2002. "The Altheim Rankine Cycle Turbogenerator 1-MWe Organic Rankine Cycle Power Plant Powered by Low-Temperature Geothermal Water." *Geothermische Energie, Mitteilungsblatt der Geothermischen Vereinigung e.v. Nr 36/37, Juni/September*, pp. 23-25.
- Green, L., 2003. Personal Communication.
- Kutscher, C., 2001. Small-Scale Geothermal Power Plant Field Verification Projects." *Geothermal Resources Council Transactions*, Vol. 25, pp. 577-580.
- Lund, J. W., 2004. "100 Years of Geothermal Power Production." *Geo-Heat Center Quarterly Bulletin*, Vol. 25, No. 1, pp. 11-19.
- Lund, J. W. and T. L. Boyd, 1999. "Small Geothermal Power Project Examples." *Geo-Heat Center Quarterly Bulletin*, Vol. 20, No. 2, pp. 9-26.
- Nichols, K., 2003. Personal Communication.
- Schochet, D. W. and H. Legmann, 2002. "Rolling Hills - Art and Geothermal Energy Meet at the World Famous Rogner Hotel and Spa Eco-Resort in Bluman, Austria." *Geothermal Resources Council Bulletin*, May/June, pp. 111-115.
- Sullivan, B., 2001. Personal Communication.